

**NOTE:**

Actual product may vary. Superlever panels are interchangeable and instructions show a product representation. Reference the SuperLever Connectors sheet for instructions and images.

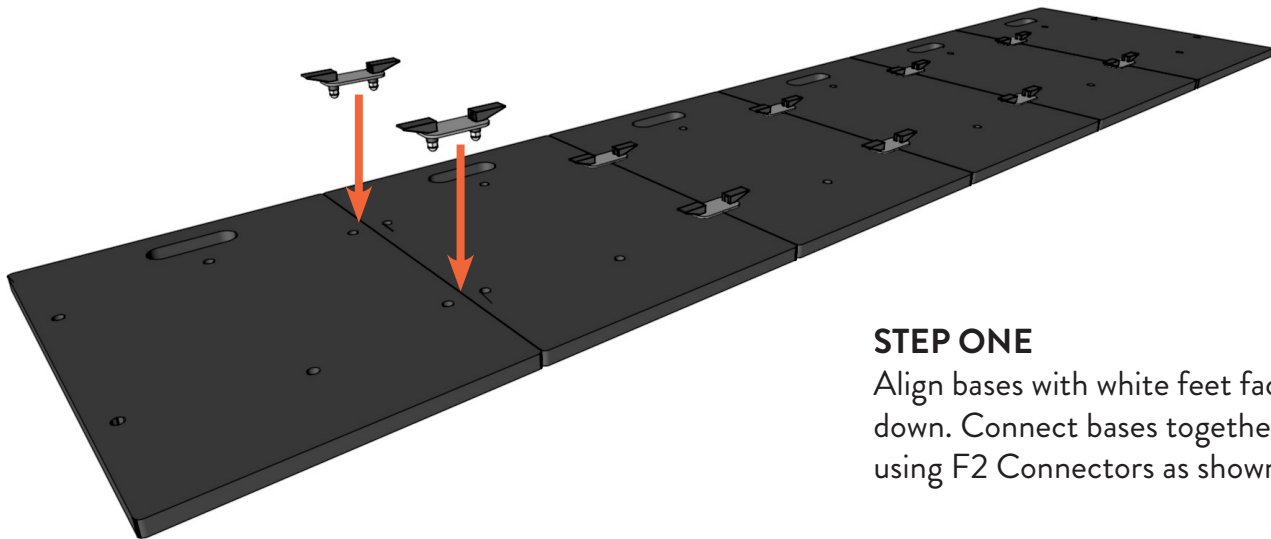

**STEP ONE**

Align bases with white feet facing down. Connect bases together using F2 Connectors as shown.

**STEP TWO**

Attach C2 and C3 Connectors using the holes in the center of each base where shown.

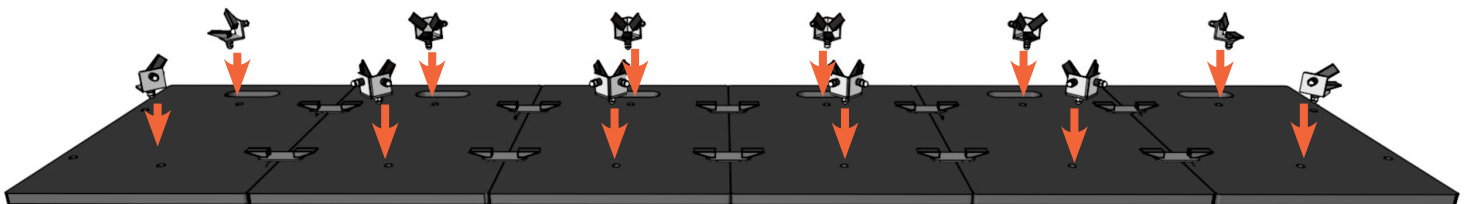

Questions about ATOMIC products?  
Contact your Modular Systems Account Manager!  
[www.atomicdesign.tv/contact](http://www.atomicdesign.tv/contact)

### STEP THREE

Risers are optional, if not using risers skip this step and continue by attaching panels to bases instead of risers. Connect risers to bases using C3 connectors and C2 connectors on each end.

#### NOTES:

Connecting C4 connectors to each riser as it is placed makes the following steps easier. If adding interior lighting to FASTwall, place lights inside risers at this point.

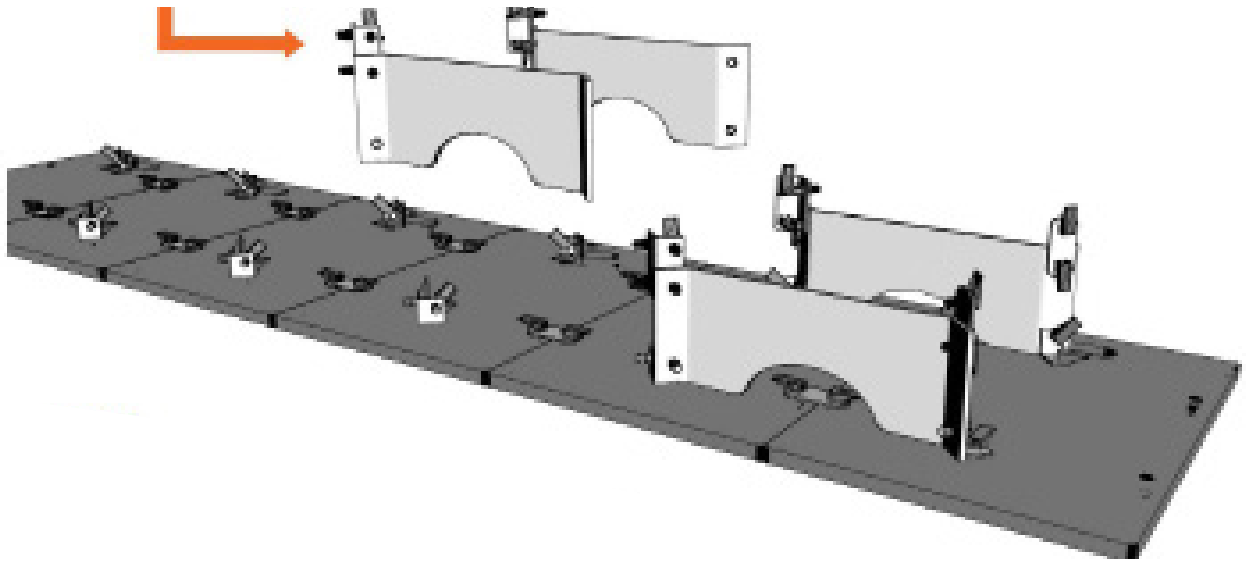

### STEP FOUR

Slide two FASTwall panels together to create one unit.

#### NOTE:

Dimensions: One FASTwall 16" Deep (22.5" Deep with bases)

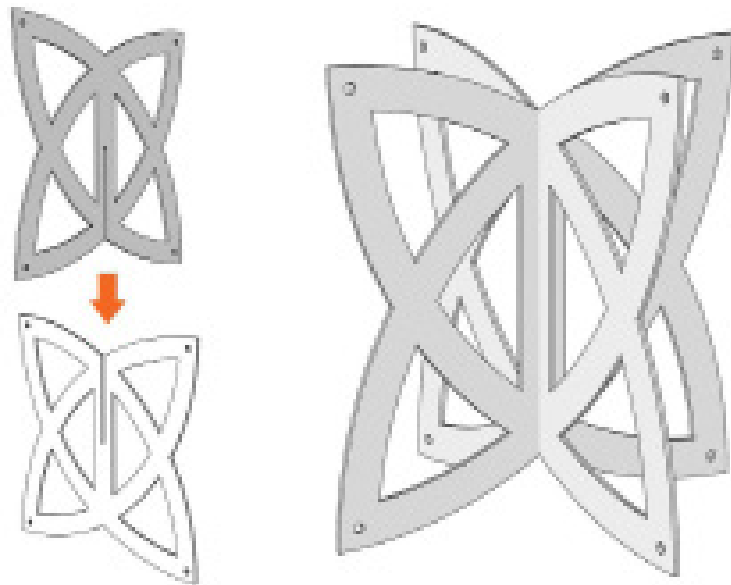

Questions about ATOMIC products?  
Contact your Modular Systems Account Manager!  
[www.atomicdesign.tv/contact](http://www.atomicdesign.tv/contact)

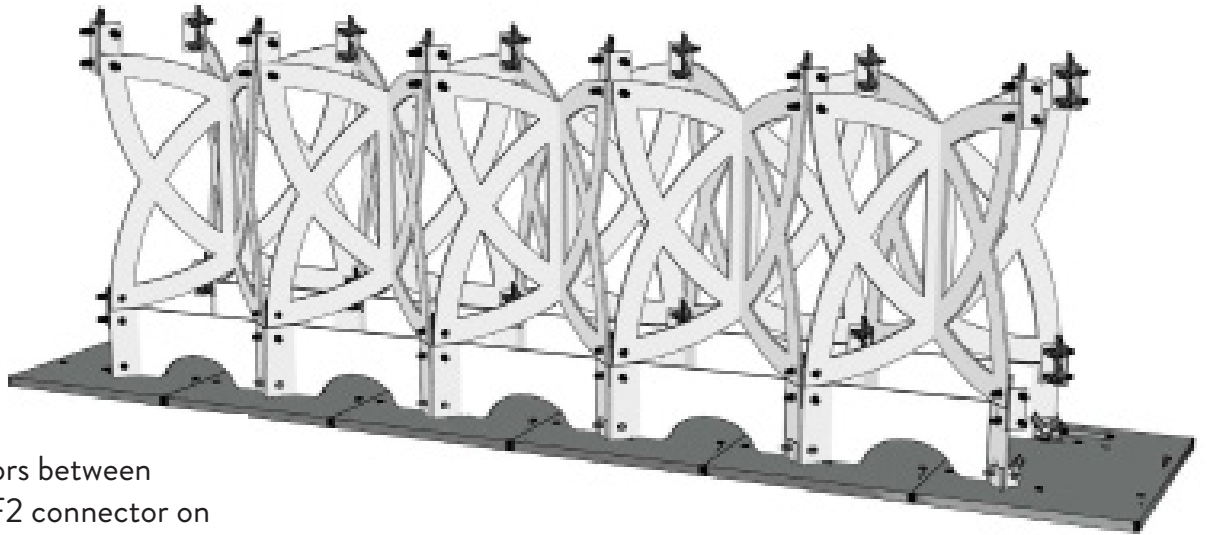

### STEP FIVE

Use C4 connectors between each panels and F2 connector on each end to continue assembling FASTwall.

### STEP SIX

Continue building FASTwall one row at a time. Finish top row with C2 connectors.

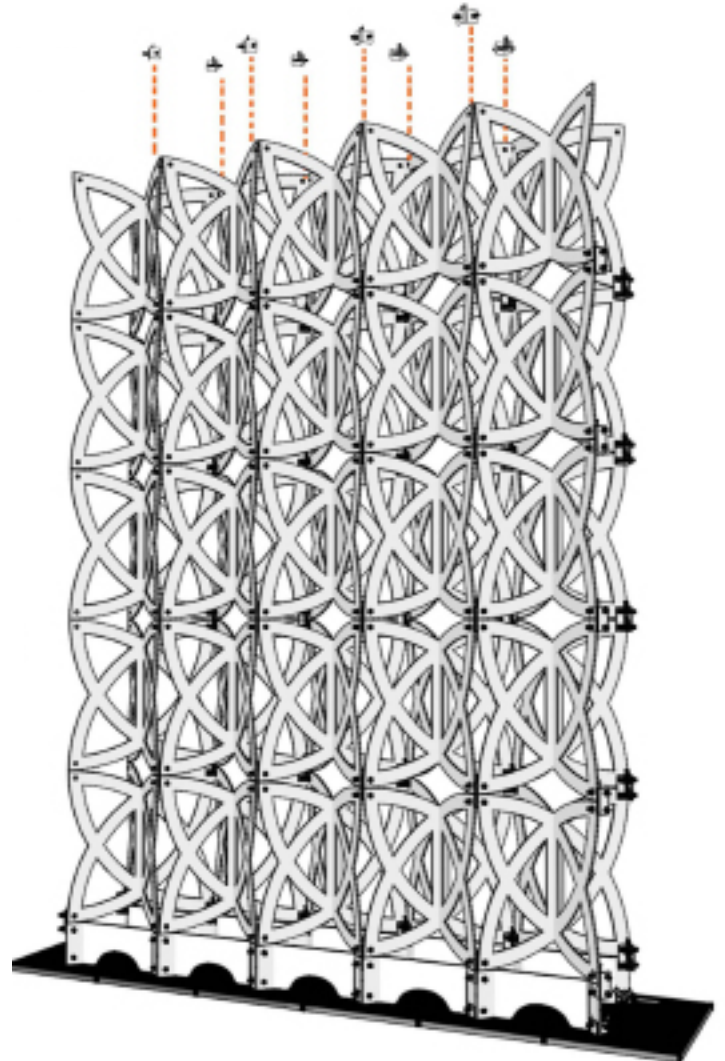

### DISASSEMBLY INSTRUCTIONS:

FASTwall **MUST** be disassembled from top down, in reverse order as the assembly process. Removal of bottom panels first may result in a toppling wall.

Questions about ATOMIC products?  
Contact your Modular Systems Account Manager!  
[www.atomicdesign.tv/contact](http://www.atomicdesign.tv/contact)